

Tvrtka Ramnes d.o.o. bavi se distribucijom proizvoda ljevaonice Bjelovar

## LINIJSKA REŠETKA 500X265 SA OKVIROM

### LINEAR GRATING 500x265 mm WITH FRAME

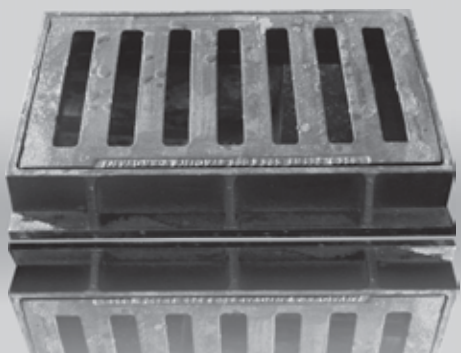

Svi proizvodi zaštićeni su zaštitnom bojom otpornom na temperaturu i koroziju. Zaštitna boja ne sadrži elemente koji bi štetno djelovali na pitku vodu.

All the products are protected with temperature and corrosion-proof protective paint, which contains no elements which are harmful for drinking water.

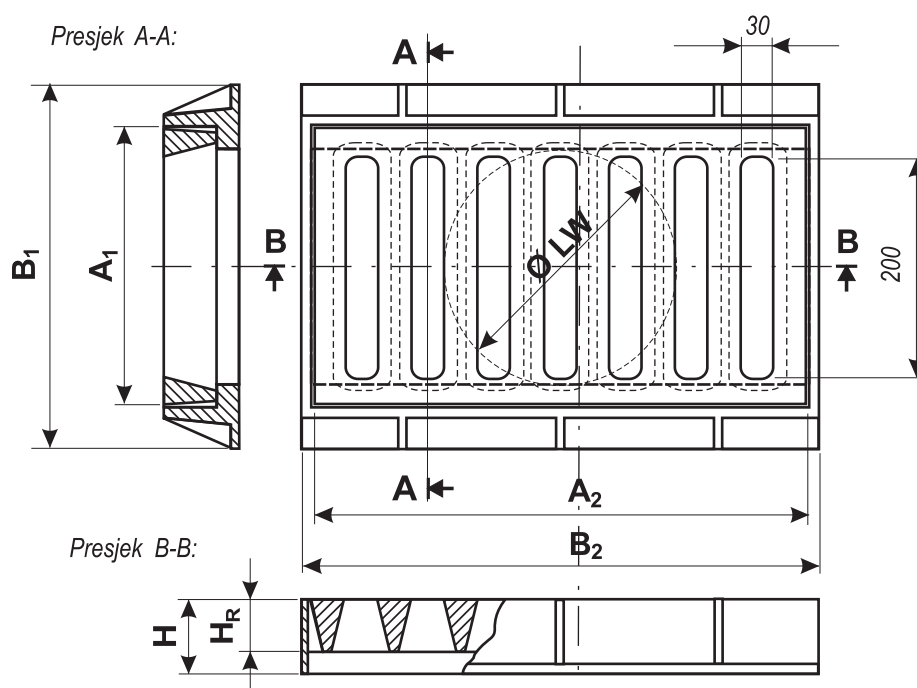

Sklopavanje rešetke i okvira:

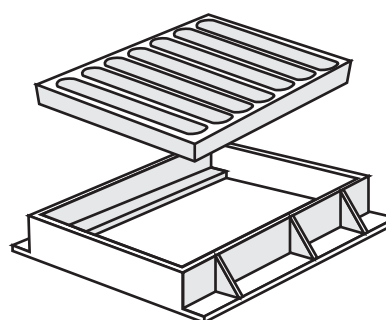

Artikl	Oznaka	Nosivost, kN		Svijetli otvor Ø LW mm	A <sub>1</sub>	B <sub>1</sub>	H mm	H <sub>R</sub> mm	Površina propusta cm <sup>2</sup>	SL	NL
		HRN EN124	HRN		A <sub>2</sub> mm	B <sub>2</sub> mm				Masa, kg/kpl	
265 B	265 x 500	B 125	150	200	$\frac{265}{450}$	$\frac{350}{480}$	70	50	402	30,5	
265 C	265 x 500	C 250		200	$\frac{265}{450}$	$\frac{350}{480}$	70	50	402		35,4