

Tvrtka Ramnes d.o.o. bavi se distribucijom proizvoda ljevaonice Bjelovar

KANALSKA REŠETKA-OVALNA 400x400 C250 SEWAGE GRATING - OVAL, 400X400 C250

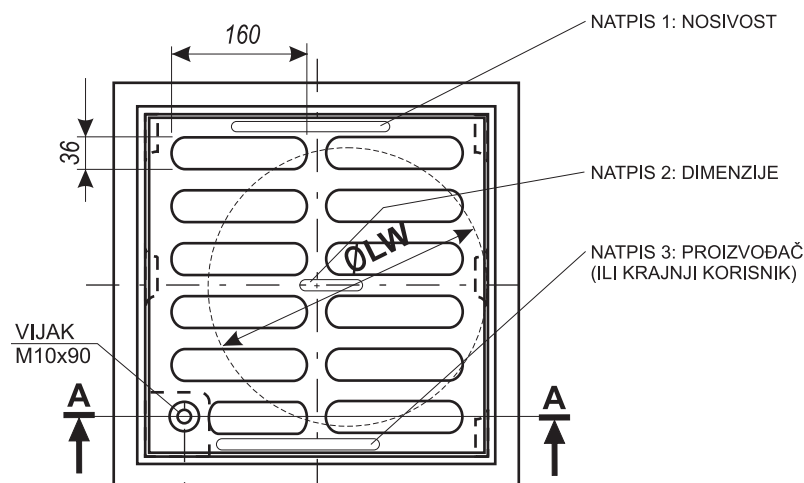

Presjek A-A:

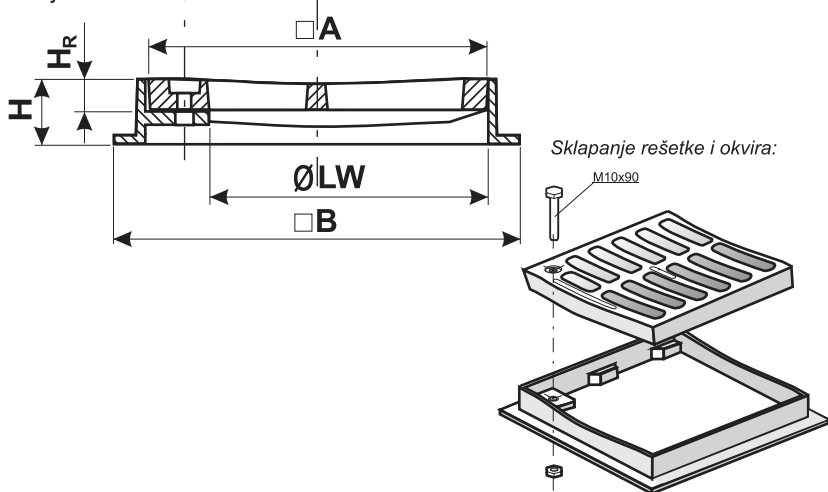

Svi proizvodi zaštićeni su zaštitnom bojom otpornom na temperaturu i koroziju. Zaštitna boja ne sadrži elemente koji bi štetno djelovali na pitku vodu.

All the products are protected with temperature and corrosion-proof protective paint, which contains no elements which are harmful for drinking water.



INSTITUT GRAĐEVINARSTVA HRVATSKE

ART.701-O - CERTIFIKAT BR. 25-041/05

Artikl	Oznaka	Nosivost, kN		Svijetli otvor ØLW mm	A	B	H	H _R	Površina propusta cm ²	SL	NL
		HRN EN124	HRN		mm	mm	mm	mm		Masa, kg/kpl	
701-O	400 x 400	C 250		345	400	495	100	40	686		39,0