

Tvrtka Ramnes d.o.o. bavi se distribucijom proizvoda ljevaonice Bjelovar

ŠKRINJICA STREET VALVE BOX



Svi proizvodi zaštićeni su zaštitnom bojom otpornom na temperaturu i koroziju. Zaštitna boja ne sadrži elemente koji bi štetno djelovali na pitku vodu.

All the products are protected with temperature and corrosion-proof protective paint, which contains no elements which are harmful for drinking water.

Materijal: SL20
 Natpis: "VODA" ili "PLIN"

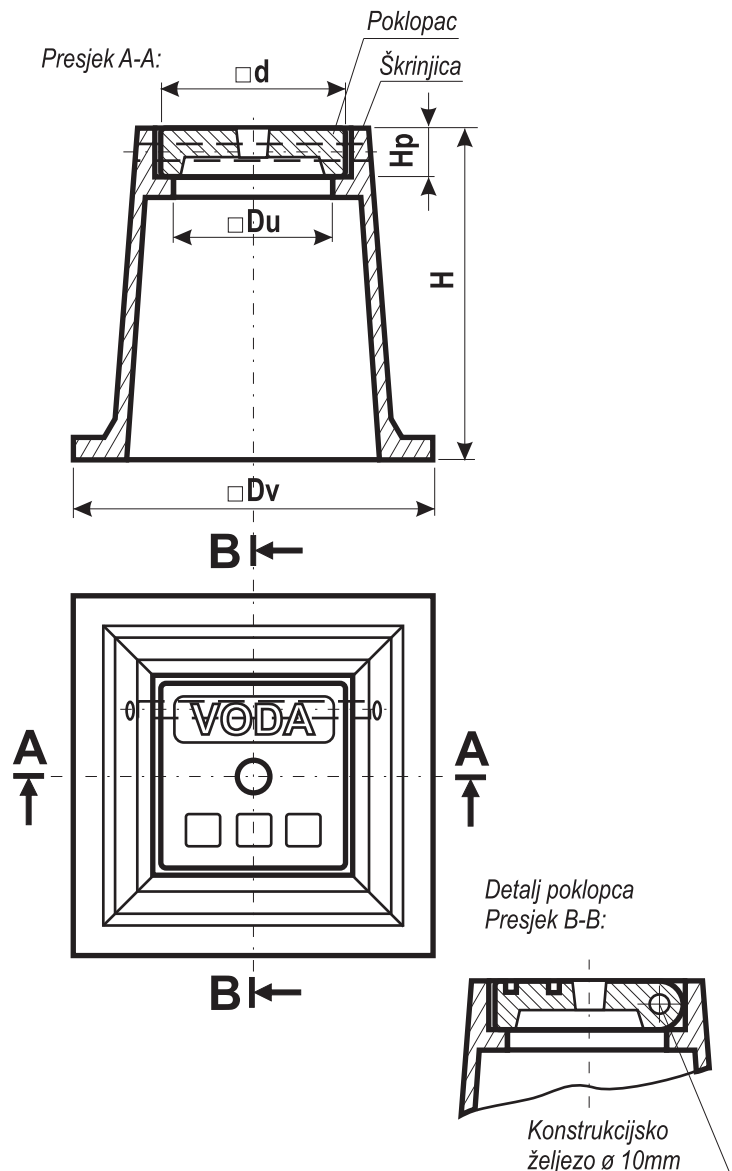

Artikl	□d	□Dv	□Du	H	Hp	Masa
	mm	mm	mm	mm	mm	kg
303	130	240	100	222	34	13,8